

SUSTAINABLE TIMES



Delivering the total package.™

QTR 3 2022 | ISSUE 15



FACILITATING THE TRANSITION TO POLYETHYLENE (PE) “DESIGN FOR RECYCLE” PACKAGING

Salted snacks, confections, salad mixes, and condiments are examples of products that are often packaged on VFFS (vertical form fill seal) machines. Compared to alternative packaging equipment, VFFS machines bring value as they minimize floor space and work well for loose, granulated, doughy, or difficult to handle materials that can offer material conveyance challenges.



Figure 1: VFFS Machine

When choosing the materials for packaging product on VFFS as well as alternative packaging equipment, there is often a balance between providing sufficient product protection, machinability, and cost. At the present time, many of the packaging materials are comprised of multi-materials where each layer of the package is optimized for certain performance characteristics. The benefit of the multi-material composition is that one can take advantage of the synergies of each material component. However, the major disadvantage is that often these multi-material laminates offer no end-of-life option and are destined for the landfill.

FACILITATING THE
TRANSITION TO PE | PG
1-3

WORLD CLEAN UP DAY |
PG 4

POST-CONSUMER
RECYCLED | PG 5

OUR MISSION | PG 5

SUSTAINABLE TIMES

FACILITATING THE TRANSITION TO PE “DESIGN FOR RECYCLE” PACKAGING

To meet sustainable goals, these laminates must often be redesigned to facilitate achieving targets such as recycling, compost, or reuse.

The transition to a more sustainable option can pose challenges to manufacturing operations as the laminates often exhibit reduced thermal stability, processability, and packaging manufacturing process challenges. With the growing interest in qualifying sustainable alternatives, packaging machine manufacturers are getting much feedback regarding the challenges in converting these sustainable options. Positive strides are being made by both the machine manufacturers and ancillary equipment providers.

Below are some equipment options being explored for VFFS (vertical, form, fill, seal) packaging equipment:

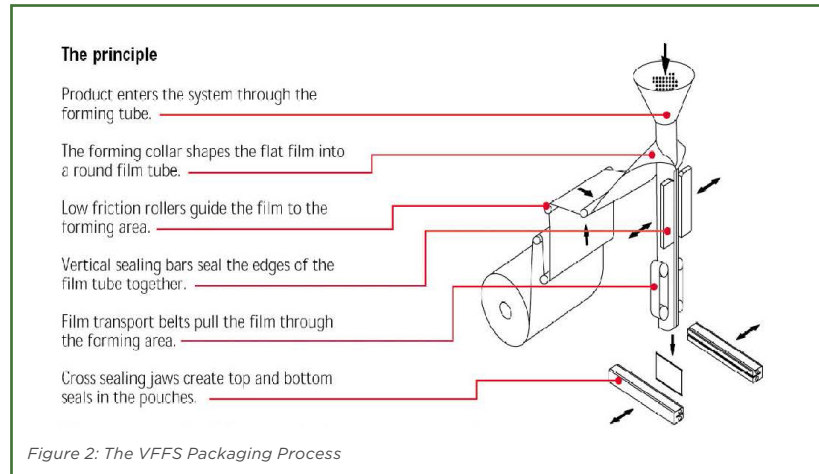

<p>SERVO MOTORS to replace traditional mechanical drive systems</p>	<p>Servo motors provide greater flexibility and can apply lower torque and speeds as the laminate is being pulled through the machine. By reducing the torque and speeds, one can minimize the propensity of the material to stretch and improve material registration.</p>
<p>RELEASE COATINGS for jaws and heat seal assemblies along with seal bar profile changes to accommodate papers and less heat resistant materials</p>	<p>One of the challenges with some sustainable materials is they don't offer comparable heat resistance to conventional offerings. This can pose issues with materials sticking to the hot seal bars. Conventionally, Teflon tape has been used as a means to reduce sticking. However, regular maintenance is required to stop the machine and replace the tape as it wears. New metal coatings are being developed and evaluated as an alternative to Teflon tapes.</p>

FACILITATING THE TRANSITION TO PE “DESIGN FOR RECYCLE” PACKAGING

<p>SEAL BARS</p>	<p>Control of heat during the sealing process is critical to achieving seals of the best quality and strength. Preferential wire elements are being evaluated which provide more uniform and stable seal system heat.</p> <p>Seal Bars with High Thermal Conductivity</p> <ul style="list-style-type: none"> • This option ensures efficient heat transfer from the heaters to the surrounding metal in the seal bar providing more consistent temperature <p>Ultrasonics</p> <ul style="list-style-type: none"> • The benefit of ultrasonics is that the technology uses ultrasonic energy at high frequencies and does not require heat. This can be a significant advantage for those materials which are heat sensitive. <p>Electronics</p> <ul style="list-style-type: none"> • New technologies are being explored which can consist of diodes which can provide variable temperature profile across the seal bar to apply heat where it is needed.
<p>ZIPPER KNOCKOUTS</p>	<p>One of the most challenging aspects of package manufacture can be the introduction of a zipper. Typical zippers have a profile which is greater in thickness than the laminate itself. To achieve an airtight pouch, the zipper must be sealed in properly to the laminate. This requires both heat and pressure to be applied to the zipper region for a certain amount of time and is often the limitation as to how fast the pouch can be manufactured.</p> <ul style="list-style-type: none"> • Exploration is beginning with knock-out systems that remove the majority of the zipper material in the pouch seal region. This can greatly improve efficiency and speed up pouch production.

Enhancing the machinability of sustainable packaging materials on converting lines is of significant focus for the machine suppliers and rest assured that there will be a great number of additional enabling technologies in the future.



WORLD CLEANUP DAY SEPTEMBER 17, 2022

On Sept 17, millions of volunteers, governments, and organizations set forth to tackle the global waste problem. In honor of this day, many APC employees volunteered their time at local community events. I want to highlight just a few of the events that occurred in honor of this day.



Figure 3: The EL&C and Chili groups in New York Cleaned up at Turning Point Park along the Genesee River in Rochester



Figure 4: The Roto team in Columbus / Deforest, Wisconsin participated in the Adopt-a-Highway roadside clean-up activity



Figure 5: The Columbus / Deforest, WI team participated in the Yahara River Clean-up. Fortunately, the amount of litter collected was limited but the group did have the opportunity to free the river from some fallen trees and obstructions.

POST-CONSUMER RECYCLED

The demand for recycled content continues to grow and the supply of mechanically recycled won't be sufficient to satisfy needs of the market. Advanced recycling, sometimes referred to as chemical or molecular recycling is ramping up and supply will only increase. However, with this technology comes new rules for traceability through the supply chain. In the next update, I will review in more detail the requirements for use of chemically recycled materials.



OUR MISSION

Sustainable Times is a quarterly newsletter compiled by American Packaging Corporation that is designed to educate, provide industry highlights and keep you informed of sustainable

solutions being developed by APC. If you have any questions, please feel free to contact your sales representative or Jeff Travis at jtravis@americanpackaging.com.